

# JOURNAL OF THE ENGINEERING MECHANICS DIVISION

## INSTABILITY, DUCTILITY, AND SIZE EFFECT IN STRAIN-SOFTENING CONCRETE

By Zdeněk P. Bažant,<sup>1</sup> M. ASCE

### INTRODUCTION

In mechanical testing of heterogeneous materials, such as concrete, the test specimen neither yields nor fails when maximum stress is reached; but a gradual decrease of stress at an increasing strain, called strain-softening, is observed. From the point of view of continuum mechanics, one particularly curious feature of this phenomenon is that of instability. It is well known (3-5,12,13,21) that any elastic or elastic-plastic material loses stability when the matrix of its tangent moduli ceases to be positive definite. On the strain-softening (declining) branch, the tangent Young's modulus is negative, which implies that the matrix of tangent moduli is not positive definite. Consequently, the specimen as well as any structure must lose stability as soon as strain-softening begins. Yet, the existence of strain-softening is an experimental fact and it would be in the interest of economy of design to take advantage of the internal force redistributions caused by strain-softening at ultimate loads. A number of studies have been devoted recently to this problem, but a mathematical formulation of the instability aspect has not been accomplished, even though many comments to this effect have been made (9,14,15,19) and some discrete models of the test specimen (22) and micromechanics models of the material (8) have been proposed.

The purpose of this paper is to demonstrate that an unstable strain localization must be considered if strain-softening is to be taken into account in a rational manner. It will be shown that ductility is determined by stability conditions and a simple way of introducing the effects of size, heterogeneity, and stored energy into the stability analysis will be suggested. The analysis will be extended to unstable curvature localization in strain-softening beams and the rotation capacity of strain-softening hinges will be expressed as a stability condition. Some consequences for the finite element solutions of limit loads of concrete

Note.—Discussion open until September 1, 1976. To extend the closing date one month, a written request must be filed with the Editor of Technical Publications, ASCE. This paper is part of the copyrighted Journal of the Engineering Mechanics Division, Proceedings of the American Society of Civil Engineers, Vol. 102, No. EM2, April, 1976. Manuscript was submitted for review for possible publication on April 25, 1975.

<sup>1</sup>Prof. of Civ. Engrg., Northwestern Univ., Evanston, Ill.

structures will also be examined. However, it will not be possible to present a complete practical design procedure; this will require inclusion of statistical

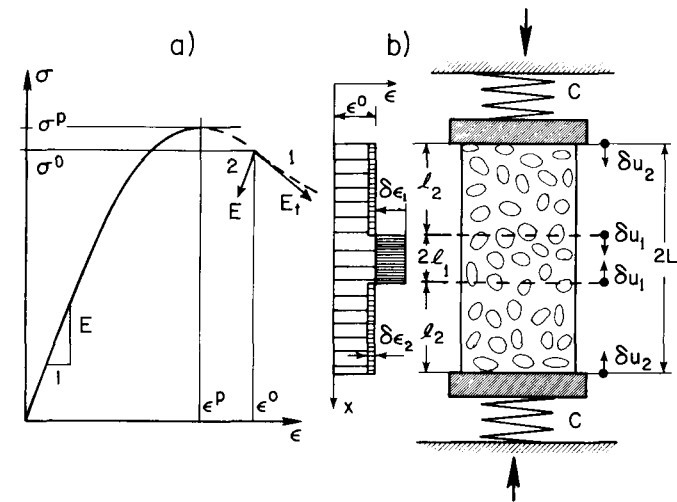

FIG. 1.—Strain Localization Mode of Instability of Strain-Softening Test Specimen

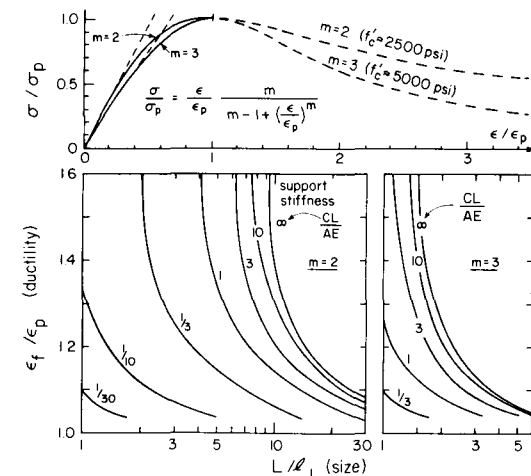

FIG. 2.—Ductility as Function of Size and Support Stiffness

nonhomogeneity into the model and possibly more extensive experimental information.

### UNSTABLE STRAIN LOCALIZATION IN UNIAXIAL DEFORMATION

Consider that the test specimen in a displacement-controlled compression test is in an equilibrium state characterized by a uniformly distributed stress  $\sigma^0$

and strain  $\epsilon^0$  corresponding to a point on the strain-softening branch (Fig. 1). Let the elastic properties of the testing machine be represented by two rigidly supported elastic springs of spring constant  $C$  (Fig. 1). To investigate stability, kinematically admissible variations of this state must be considered. Attention will be restricted herein to such variations in which all cross sections remain planar. A segment of length  $2l_1$  (Fig. 1) is assumed to undergo a uniform infinitesimal strain increment  $\delta\epsilon_1$  (which represents strain-softening) and the remaining segments of length  $l_2$  (Fig. 1) are assumed to undergo a uniform infinitesimal strain increment,  $\delta\epsilon_2$ , which represents unloading. This incremental deformation, which may be called longitudinal instability mode, is fully characterized by cross-sectional displacements  $\delta u_1$  and  $\delta u_2$  shown in Fig. 1. The deformation mode in Fig. 1 is pictured as symmetric along the axis, but the analysis which follows is valid just as well for asymmetric segments  $l_1$  and  $l_2$  and can be easily extended to subdivisions with a greater number of segments.

Assuming that the material is sufficiently characterized by the uniaxial stress-strain relation, the work that must be supplied to the system specimen-loading frame in order to effect the postulated variation of the initial equilibrium state is

$$\Delta W = 2 \left[ Al_1 \left( \sigma^0 + \frac{1}{2} E_t \delta\epsilon_1 \right) \delta\epsilon_1 + Al_2 \left( \sigma^0 + \frac{1}{2} E \delta\epsilon_2 \right) \delta\epsilon_2 + \left( P^0 + \frac{1}{2} C \delta u_2 \right) \delta u_2 \right] \dots \dots \dots (1)$$

in which  $A$  = cross-sectional area of the specimen;  $P^0 = A\sigma^0$ ;  $E_t$  = tangent modulus of the strain-softening branch at point  $\epsilon^0$ ,  $\sigma^0$  (Fig. 1) and  $E$  = modulus for unloading at decreasing strain, which approximately equals the elastic modulus,  $E$ , of an unstressed specimen before the test. The work done by the drive of the machine is not included in Eq. 1 because  $\delta u_1$  and  $\delta u_2$  are arbitrarily small and thus can occur within an arbitrarily short time in which the work of the drive is negligible.

The compatibility of deformations  $\delta\epsilon_1$  and  $\delta\epsilon_2$  with support conditions requires that  $\delta u_2 = -l_1 \delta\epsilon_1 - l_2 \delta\epsilon_2 = 0$ , and so Eq. 1 becomes

$$\Delta W = Al_1 E_t (\delta\epsilon_1)^2 + Al_2 E (\delta\epsilon_2)^2 + C(l_1 \delta\epsilon_1 + l_2 \delta\epsilon_2)^2 + \delta W \dots \dots \dots (2)$$

in which  $\delta W = 2A\sigma^0(l_1 \delta\epsilon_1 + l_2 \delta\epsilon_2 + \delta u_2) = 0$ . It follows from the virtual work principle applied to the initial equilibrium state that the linear terms represented by  $\delta W$  must vanish. Eq. 2 may be rewritten as a quadratic form

$$\Delta W = \sum_{i=1}^2 \sum_{j=1}^2 a_{ij} \delta\epsilon_i \delta\epsilon_j \dots \dots \dots (3)$$

with coefficients  $a_{ij}$  which may be arranged in the following matrix:

$$[a_{ij}] = \begin{bmatrix} AE_t l_1 + Cl_1^2, & Cl_1 l_2 \\ Cl_1 l_2, & AE l_2 + Cl_2^2 \end{bmatrix} \dots \dots \dots (4)$$

Eq. 3 may further be put in the form

$$\Delta W = a'_{11} (\delta\epsilon_1)^2 + a'_{22} \left( \delta\epsilon_2 + \frac{a_{12}}{a_{22}} \delta\epsilon_1 \right)^2 \dots \dots \dots (5)$$

$$\text{in which } a'_{11} = \frac{a_{11} a_{22} - a_{12}^2}{a_{22}}, a'_{22} = a_{22} \dots \dots \dots (6)$$

A system is in a stable state when work must be supplied to the system ( $\Delta W > 0$ ) during any kinematically admissible variation of its state. This means that the variation cannot happen spontaneously, if the work required is not supplied. When some kinematically admissible variation of displacements can be found for which work is released by the system, i.e.,  $\Delta W < 0$ , then the system is *unstable* and the variation of displacements will happen spontaneously, work ( $-\Delta W$ ) being released as kinetic energy and ultimately transformed into heat ( $\Delta Q = -\Delta W$ ) and dissipated. In fact, it follows directly from the second law of thermodynamics that a release of work or heat will occur whenever it can occur. Consequently, the test specimen will fail, due to instability, when a negative value of  $\Delta W$  becomes possible, i.e., when the quadratic form in Eq. 5 or Eq. 3 ceases to be positive definite. Because  $a'_{22} = a_{22} = AE l_2 + Cl_2^2$  is always positive, the only manner in which the quadratic form in Eq. 5 can become negative is by  $a_{11} a_{22} - a_{12}^2$  or  $\det(a_{ij})$  turning negative, i.e.

$$(AE_t l_1 + Cl_1^2)(AE l_2 + Cl_2^2) - C^2 l_1^2 l_2^2 < 0 \dots \dots \dots (7)$$

which (after substituting  $l_2 = L - l_1$ ) yields the condition of instability (failure):

$$\frac{-E_t}{E} > \frac{-E_{t_{crit}}}{E} = \frac{1}{\frac{L}{l_1} - 1 + \frac{AE}{Cl_1}} \dots \dots \dots (8)$$

When  $\Delta W = 0$ , the specimen is in the state of neutral equilibrium (or bifurcation of equilibrium path), the occurrence of which can alternatively be determined from equilibrium considerations. The specimen will remain in equilibrium after the displacement variation if  $\delta\sigma_1 = \delta\sigma_2$  and  $A\delta\sigma_1 = \delta P_C$  in which  $\delta\sigma_1 = E_t \delta\epsilon_1$ ,  $\delta\sigma_2 = E \delta\epsilon_2$ ,  $\delta P_C = C \delta u_2 = -C(l_1 \delta\epsilon_1 + l_2 \delta\epsilon_2)$ . These conditions yield a system of two algebraic linear homogeneous equations for  $\delta\epsilon_1$  and  $\delta\epsilon_2$ :

$$E_t \delta\epsilon_1 - E \delta\epsilon_2 = 0; (AE_t + Cl_1) \delta\epsilon_1 + Cl_2 \delta\epsilon_2 = 0 \dots \dots \dots (9)$$

A nonzero solution is possible if, and only if, the determinant of this equation system vanishes. This condition leads to Eq. 8 with inequality replaced by equality, and obviously this result is the same as that ensuing from  $\Delta W = 0$ .

The most serious limitation of the preceding analysis of instability is the assumption of uniaxial stress-strain relation, which disregards incompatibility of lateral strains between segments  $l_1$  and  $l_2$ . This assumption should be satisfactory if the specimen is not too short. For short specimens it would be necessary to consider a two or three-dimensional (bulging) mode of inelastic instability with unloading, similar to the elastic instability of thick rectangular solids (3-5). This represents a very complex problem, at present remaining unsolved. From experiments, the ultimate failure mode is known to be either axial splitting or propagation of an inclined shear band, rather than the mode in Fig. 1.

The foregoing analysis also applies when, in a slab under in-plane compression  $\sigma_x$ , the declining branch is reached within a certain failure band (of width  $2l_1$ ) spreading along the slab in the  $y$  direction. In this case the appropriate  $\sigma_x - \epsilon_x$  relationship is that for  $\epsilon_y \approx 0$  and  $\sigma_z = 0$ . The error due to the disparity of lateral strains  $\epsilon_z$  is, in this case, probably less significant than that due to the disparity of both  $\epsilon_y$  and  $\epsilon_z$  in uniaxial compression ( $\sigma_y = \sigma_z = 0$ ). The remaining simple case in which compression  $\sigma_x$  is applied at  $\epsilon_x = \epsilon_y = 0$  can probably never lead to strain-softening. The case of strain-softening of concrete in shear within a band (of width  $2l_1$ ) spreading across a concrete mass can be analyzed similarly, replacing the  $\sigma - \epsilon$  relationship by a  $\tau - \gamma$  relationship. The tensile failure of concrete can be regarded as a limiting case of strain-softening in which  $E_t$  tends to  $-\infty$ .

The points on the declining branch represent states that cannot exist permanently because concrete undergoes intense creep or relaxation and is not in a thermodynamic equilibrium. Yet the foregoing analysis is applicable because the state of initial static equilibrium exists, in the sense that inertia forces are negligible. The tangent modulus,  $E_t$ , must be evaluated as the effective sustained modulus for the anticipated duration of load.

**Effect of Size and Stored Energy on Ductility.**—Whenever positive  $l_1$  can be found, such that Eq. 8 is fulfilled, the specimen is *unstable* and fails. On the rising branch ( $E_t > 0$ ), Eq. 8 cannot be satisfied for any positive  $l_1$ , which guarantees stability. However, on the strain-softening branch ( $E_t < 0$ ), the left-hand side of Eq. 8 is positive and the right-hand side can be made arbitrarily small when  $l_1$  is sufficiently small, and so Eq. 8 can always be satisfied, which implies instability. This leads to the conclusion that, in a continuum, the strain-softening is impossible.

Yet, it is a well-established experimental fact that a stable equilibrium on the strain-softening branch is possible (17). The reason for this apparent contradiction has to be sought in the assumption that the material is a continuum. From experiments it is well known that strain-softening can be observed only on small enough specimens of heterogeneous materials, such that the size of inhomogeneities (e.g., size of aggregate in concrete) is not too small as compared with the size of specimen. The assumption of a homogeneous strain state within the strain-softening segment of length  $l_1$  (Fig. 1) is admissible only when  $l_1 \geq nd$ ,  $d$  being the maximum size of aggregate and  $n$  an empirical coefficient greater than one; probably  $2 \leq n \leq 20$ . Thus, the smallest possible value of the right-hand side of Eq. 8 is finite and is obtained by substituting

$$l_1 = nd \quad \dots \dots \dots (10)$$

This means that instability or failure on the strain-softening branch occurs only at a strain  $\epsilon_f$  for which the downward slope reaches a certain critical value. The ratio of failure strain  $\epsilon_f$  to strain  $\epsilon_p$  at peak stress may be regarded as a measure of ductility. When  $\epsilon$  exceeds  $\epsilon_p$ , the downward slope increases as  $\epsilon/\epsilon_p$  increases. Thus, according to Eq. 8, ductility  $\epsilon_f/\epsilon_p$  is less for a longer specimen and also for a smaller spring constant  $C$  of the support. Since the energy stored in the system specimen-spring increases with the flexibility of support, ductility  $\epsilon_f/\epsilon_p$  is less for a higher stored energy. These trends agree with experimental evidence (10,11).

To quantify the foregoing considerations, consider the stress-strain relation (Fig. 2)

$$\sigma = \frac{m}{m-1} \frac{\sigma_p}{\epsilon_p} \left( \frac{\epsilon}{\epsilon_p} \right)^m \quad \dots \dots \dots (11)$$

which describes quite closely the observed strain-softening diagrams for concrete (17). Exponent  $m$  depends mainly on strength  $f'_c$  of concrete;  $m \approx 2$  for  $f'_c = 2,500$  psi (17.2 MN/m<sup>2</sup>) and  $m \approx 3$  for  $f'_c = 5,000$  psi (34.5 MN/m<sup>2</sup>). Calculating tangent modulus  $E_t = d\sigma/d\epsilon$  from Eq. 11 and setting  $m\sigma_p/\epsilon_p = E$ , it follows:

$$\frac{-E_{t,crit}}{E} = \frac{(m-1) \left[ \left( \frac{\epsilon}{\epsilon_p} \right)^m - 1 \right]}{\left[ m-1 + \left( \frac{\epsilon}{\epsilon_p} \right)^m \right]^2} \quad \dots \dots \dots (12)$$

Substituting this expression into Eq. 8, a nonlinear equation for  $\epsilon = \epsilon_f$  is obtained. Values of ductility  $\epsilon_f/\epsilon_p$  calculated numerically from this equation for various values of the size parameter,  $L/l_1$ , and the relative stiffness of support,  $CL/AE$ , are plotted in Fig. 2.

**Statistical Aspects.**—The strain-softening is known to be a rather elusive phenomenon which may or may not be observed depending on the testing method. Thus, doubts exist as to the possibility of regarding the strain-softening as a real property of concrete. The difficulty consists in the dichotomy between the limiting process defining a continuum and the finite dimensions required for the average (macroscopic) conditions in a composite, such as concrete.

The strain-softening branch can be considered to be a real property of concrete if it is defined on the basis of the average value of the total forces acting on the surfaces of a great number of small specimens which are only a few aggregate diameters in size and are subjected on their boundaries to equal uniform displacements. However, it must be kept in mind that the statistical scatter of the stresses with regard to their average value also affects the  $\sigma - \epsilon$  diagram. In contrast to the present model, the statistical scatter, which is not analyzed herein, can explain the effect of size upon strength (peak stress,  $\sigma_p$ ); see Ref. 20 as well as the model of parallel elements in Ref. 8 for the effect of the statistical distribution of the strength of microelements of the material. On the other hand, the statistical theories, do not predict the point of instability, which in turn governs ductility. For example, the model of parallel elements in Ref. 8 does allow strain-softening regardless of size, while the present model, which represents a "series" model, does not.

The basic assumptions required by the statistical nonhomogeneity and by the stability condition are in conflict; the former allows the material to be considered as a continuum only on a sufficiently large scale, while the latter requires the material element to be sufficiently small. The present analysis implies the assumption that a certain size exists such that the material element may be approximately treated as an element of a continuum and at the same time be small enough to prevent instability. To set up a rigorous theory, it will

be necessary to synthesize the present stability formulation and the statistical formulation.

**UNSTABLE CURVATURE LOCALIZATION IN STRAIN-SOFTENING BEAMS**

Consider a beam (Fig. 3) which forms part of a frame or a continuous beam, or is fixed at the ends. Let the elastic stiffness of adjacent beams be characterized

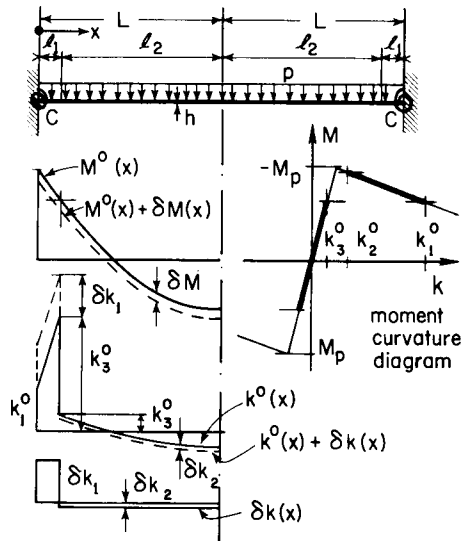

**FIG. 3.—Curvature Localization Mode  $\delta k$  of Instability of Strain-Softening Beam**

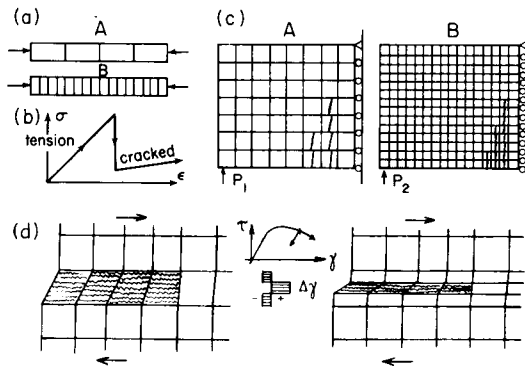

**FIG. 4.—Examples of Structural Problems in which Strain-Softening or Cracking Causes Spurious Dependence on Finite Element Size**

by rotational springs of spring constants  $C$  (Fig. 3). Denote  $2L =$  span of the beam and assume that the cross section is uniform and exhibits an idealized bilinear moment-curvature diagram shown in Fig. 3. Assume that the beam

has already reached a state of curvature distribution,  $k^0(x)$ , and bending moment distribution  $M^0(x)$ , such that segments of length  $l_1$ , shown in Fig. 3, are on the strain-softening branch. Note that at the end of segment  $l_1$  the curvature  $k$ , must exhibit discontinuity (Fig. 3) and, therefore, segment  $l_1$  is called the discontinuity length (1,2,19). For the sake of simplicity, the beam is assumed to remain in a symmetric state at all times.

Consider now that a curvature variation,  $\delta k(x)$  (Fig. 3), and end rotations,  $\delta\phi$ , are superimposed on the initial state, without changing the applied loads. Let end rotations  $\delta\phi$  represent an unloading of the adjacent beams and choose  $\delta k(x)$  to be piece-wise constant, with values  $\delta k_1$  and  $\delta k_2$  in segments 1 and 2 (Fig. 3). Assume that  $\delta k_1$  is an increase of curvature (strain-softening) and  $\delta k_2$  is either an unloading or an elastic loading (rising branch); this is possible only if the positive moments are all on the rising branch. The deformation mode,  $\delta k(x)$ , may be described as curvature localization. Its existence is corroborated by Barnard's experimental observation (1,2) that the discontinuity length shortens prior to failure.

The work that must be supplied to effect the postulated variation of curvatures while keeping the loads constant is

$$\Delta W = M^0(0) + \frac{1}{2} (C\delta\phi) \delta\phi + \int_0^L \left[ M^0(x) + \frac{1}{2} \delta M(x) \right] \delta k(x) dx - \int_0^L p^0(x) \delta w(x) dx; \text{ or}$$

$$\Delta W = \frac{1}{2} (C\delta\phi) \delta\phi + \frac{1}{2} \int_0^L \delta M(x) \delta k(x) dx + \delta W \dots \dots \dots (13)$$

in which  $\delta M(x)$  and  $\delta w(x) =$  variations of moments  $M$  and deflections  $w$  which accompany  $\delta k(x)$ ; and  $\delta W =$  virtual work of an equilibrium system of forces, which must vanish ( $\delta W = 0$ ). Variations  $\delta M(x)$  may be expressed as  $R_t \delta k_1$  within segment 1 which softens and  $R \delta k_2$  within segment 2 which unloads,  $R_t$  and  $R$  being the incremental bending rigidities of cross sections in strain-softening ( $R_t < 0$ ) and in unloading ( $R > 0$ ). Eq. 13 then becomes  $2\Delta W = C(\delta\phi)^2 + l_1 R_t (\delta k_1)^2 + l_2 R (\delta k_2)^2$ . Furthermore, the condition of zero slope at the midspan requires that  $\delta\phi + \int_0^L \delta k(x) dx = 0$  or  $\delta\phi = -l_1 \delta k_1 - l_2 \delta k_2$ , which renders Eq. 13 in the form

$$\Delta W = (R_t l_1 + C l_1^2) (\delta k_1)^2 + 2 C l_1 l_2 \delta k_1 \delta k_2 + (R l_2^2 + C l_2^2) (\delta k_2)^2 \dots \dots \dots (14)$$

This is a quadratic form and further considerations may proceed in the same manner as those which led from Eq. 3 to Eq. 9. Instability is thus found to occur when the determinant of the quadratic form coefficients becomes negative, i.e.

$$(R_t l_1 + C l_1^2) (R l_2 + C l_2^2) - C^2 l_1^2 l_2^2 < 0 \dots \dots \dots (15)$$

Upon substituting  $l_2 = L - l_1$ , this yields the condition of instability

$$\frac{-R_t}{R} > \frac{-R_{t,crit}}{R} = \frac{1}{\frac{L}{l_1} - 1 + \frac{R}{C l_1}} \dots \dots \dots (16)$$

which is similar to Eq. 8. Equality in this relation represents the condition of neutral equilibrium (bifurcation of equilibrium path). This condition may be also deduced from the incremental equilibrium relations,  $\delta M_1 = \delta M_2$  and  $\delta M_1 = C\delta\phi$ , in which  $\delta M_1 = R\delta k_1$  and  $R_2 = R_1 \delta k_2$  (similar to Eq. 9).

For  $R_t < 0$  it is always possible to satisfy Eq. 16 by choosing a sufficiently short strain-softening segment,  $l_1$ . Therefore, a perfectly homogeneous and infinitely slender beam cannot exhibit strain-softening and thus a strain-softening plastic hinge, which represents the limiting case  $l_1 \rightarrow 0$ , cannot exist.

However, strain-softening can be observed in experiments and the explanation must again be sought in the size effect. Segment  $l_1$  must, of course, be greater than several sizes of the aggregate; but this condition still yields the softening segment too short for allowing any significant strain-softening of the beam. In case of a beam, however, segment  $l_1$  may not be smaller than either spacing of stirrups or  $nh$ ,  $h$  being the depth of a beam and  $n$  a small empirical coefficient (equal perhaps 1 to 3), because for shorter segments the bending theory cannot be assumed to hold and two-dimensional deformation states would have to be considered. The failure condition is obtained by setting in Eq. 16

$$l_1 = nh \quad \dots \dots \dots (17)$$

Eq. 16 is based on an idealized bilinear moment-curvature diagram (Fig. 3) and because its strain-softening branch has constant slope, failure is always obtained at the point of peak moment. In reality, the downward slope increases beyond the peak point gradually; but for such a stress-strain diagram the exact criterion for instability would be considerably more complex than Eq. 16. Nevertheless, Eq. 16 should still be approximately applicable even in this case, assuming that the negative tangent rigidity,  $R_t$ , is the same in all cross sections of segment  $a$  and equals the correct value for the middle of segment  $a$ , and that  $R$  represents the average value of tangent bending rigidities (for either the rising branch or for unloading) over the rest of the beam. Under this assumption the diagram for bending ductility of strain-softening segments would have the same form as that in Fig. 2.

Applying Fig. 2 to beams, it follows that the possible extent of moment redistribution is less for slender beam and also for a beam with a smaller stiffness of the adjacent structure. For example, a fixed-end beam allows greater moment redistribution than a beam that is part of a continuous beam or frame and has exactly the same bending moments as the fixed-end beam.

The instability due to strain-softening has been analyzed so far (14,15) only under the tacit assumption that the plastic hinge rotations fully characterize all possible incremental deformations; but this is not true because distributed curvature increments such as  $\delta k$  in Fig. 3 are excluded, with the consequence that all possible instabilities are not revealed. In a number of studies (9), finite elements of a beam and a step-by-step loading process have been utilized to calculate the collapse load in presence of strain-softening. However, checks for all possible distributions of curvature increments have not been made in these studies. Based on the present results, a check for instability must be included at each loading step. This may be approximately accomplished by means of Eq. 16. Alternatively, in a finite element analysis of a beam or frame, the attainment of the neutral equilibrium state (or bifurcation of equilibrium path,  $\Delta W = 0$ ) may also be determined by checking at each loading stage

for a zero value of the determinant of the incremental stiffness matrix. However, it is insufficient to check it only for one loading path; a number of possible forms of the stiffness matrix, corresponding to various possible combinations of loading and unloading tangent bending rigidities and rising branch rigidities in individual finite elements, must be considered at each loading stage. Furthermore, along the anticipated discontinuity length, the finite element subdivision must be sufficiently fine or the curvature localization into a very short segments will be missed.

**Paradox of Strain-Softening in Beams.**—The manner in which the state of discontinuous curvature distribution in strain-softening beams [such as  $k^0(x)$  in Fig. 3] can be attained has been considered to be a paradox of limit analysis with stress-softening (see p. 684 of Ref. 24). It was argued that in theory the strain-softening states can never be reached, because immediately after the end cross sections reach the peak moment, the moment at end cross sections must decrease, which means that the moment in the adjacent cross sections that have not yet reached the peak moment curvature may only decrease, and may thus never reach the peak. However, this argument is fallacious in that it disregards the possibility of superimposed piece-wise constant discontinuous curvature increments [ $\delta k(x)$  in Fig. 3]. These do enable the adjacent cross sections to reach the peak moment and transit to the softening branch. In particular, right after the end cross sections reach the peak moment,  $\delta k(x)$  occurs with a segment,  $l_1$ , of zero length, and subsequently this segment extends as the peak moment moves on further loading away from the support. Such short values of segment  $l_1$  are, of course, only theoretical because a finite change in curvature can in reality occur only over a finite length equal to  $nh$  (Eq. 17), and it is only when the peak moment moves distance  $nh$  from the support that an instability is possible in a beam of finite depth  $h$ . Thus, it appears that the present analysis removes what has been considered a paradox in strain-softening of beams.

#### REMARKS ON LIMIT ANALYSIS BY FINITE ELEMENT METHODS

As has been shown, strain-softening is impossible without heterogeneity of the material. This represents a certain inconsistency in the mathematical model, because by characterizing the strain-softening in terms of stress and strain, the state variables of a continuous medium, one implies the material to be a continuum, and this property is incompatible with the existence of strain-softening. One way to circumvent this inconsistency is to describe the strain-softening by means of a stress-displacement, rather than stress-strain relation, the displacement being a relative displacement over a certain characteristic length,  $l_1 = hd$ . The mode of instability due to strain-softening may be described as strain-localization (a tendency of strain to localize within a short segment  $l_1$ ).

When the thickness of the region into which the deformation in presence of strain-softening tends to localize is relatively small, there is an almost discontinuous jump in the distribution of displacement across this region. This is similar to the situation in brittle fracture, which exhibits a jump in displacement across the crack. Therefore, the effect of strain-softening and the propagation of strain-softening regions across a sufficiently large two or three-dimensional concrete structure should be treated in terms of a singular stress field and a certain associated stress intensity factor, similarly as in the theory of brittle

fracture. Instability of clay slopes due to propagation of strain-softening shear bands has been treated in this manner by Rice (16,18). A similar shear-strain localization [see Fig. 4(d)] is undoubtedly also possible in concrete. The stress intensity factor is applicable only if the structure is of sufficiently large size, as compared to the width of the localized strain region, i.e., to the size of the aggregate. For tensile failure of mortar, this has been experimentally demonstrated by Walsh (23). In the case of reinforced concrete, the structure must be also large with respect to the spacing of reinforcing bars, whose presence tends to increase the thickness of the region into which the deformation can localize. A gravity dam, and perhaps also a prestressed concrete reactor vessel, are examples of a sufficiently large concrete structure.

In small structures, however, the deformation cannot localize into sufficiently thin regions because the size of aggregate and the spacing of reinforcement is not small enough relative to the dimensions of the structure. In such cases, which include most concrete beams and slabs, the assumption of stress fields with singularities would certainly be inappropriate. Probably the best approach is the finite element analysis as presently used, with the condition of strain-softening, cracking, or failure formulated in terms of the stress in the finite element. However, the finite elements that exhibit strain-softening must have precisely the proper size relative to the size of aggregate. If finite elements of reinforced concrete are considered, they must have the proper size relative to the spacing of reinforcement. What the proper size is, remains to be determined experimentally.

To illustrate the effect of the choice of the finite element size, consider the crude element subdivision A in Fig. 4(a). The strain-softening region is prevented to have its size,  $l_1$ , smaller than the size of the finite element, and therefore the instability which may in reality occur for smaller  $l_1$  cannot be detected in the finite element analysis, even if complete stability checks are made at each loading step. It is thus clear that the calculated strains and loads at failure can be entirely different for the finite element subdivisions A and B in Fig. 4(a). When tensile cracking is modeled in the finite element analysis, the situation is similar because the drop of stress due to tensile cracking can be viewed as a limiting case of strain-softening in which the slope of the declining branch approaches the vertical [Fig. 4(b)]. When the finite element at the front of the cracked (or softening) zone is subdivided into smaller elements, the deformation will always localize into one of them [Fig. 4(d)], and when these finite elements are made sufficiently small the tensile stress in the finite element just ahead of the cracked (or softening) band can be made as large as desired; conversely, if the condition of cracking (or strain-softening) is expressed in terms of stress and strain, the crack band can be made to propagate under a load as small as desired. For example, in reinforced concrete panels (7), the cracked band in the fine finite element mesh B in Fig. 4(c) would propagate at a load that is smaller than the load that would cause propagation of the cracked band in the coarse mesh A in Fig. 4(c). These are unacceptable features which violate the condition that the results of failure analysis must be independent of the analyst's will (principle of objectivity).

If the reinforcement is very heavy, the ultimate load depends on the reinforcement much more than on the tensile strength of concrete. Since the reinforcement does not exhibit any softening, the aforementioned effect of finite

element size in the analysis of tensile cracking is mitigated; but then one would obtain nearly the same result treating concrete as a material of zero tensile strength, in which no tensile strain-softening exists.

Frequently, it is not certain whether the failure condition in terms of the stress and strain or the failure condition in terms of the stress-intensity factor should be applied. In such cases both conditions should be checked and only when *both* indicate propagation, the extension of the cracked or softening band into the next finite element should actually be implemented.

#### SUMMARY AND CONCLUSIONS

Strain-softening is impossible in a continuum because it causes instability; it can exist only in a heterogeneous material. Failure occurs by an unstable localization of strain or beam curvature in which the stored strain energy of the structure is transferred into a small strain-softening region, whose size is in concrete several times the aggregate size, in reinforced concrete several times the spacing of reinforcement, and in beams several times their depth. The existence of a lower limit on the size of this region permits ductility, along with its dependence on the size and stored energy, to be predicted by a stability analysis. Stability checks of possible curvature localization must be included when calculating the limit loads and moment redistributions in strain-softening concrete beams and frames. This is also true of finite element analyses of reinforced concrete structure with account of tensile cracking. Predictions of limit loads by these analyses depend, possibly quite strongly, on the chosen size of finite elements. The proper size to be used must be determined experimentally.

#### ACKNOWLEDGMENT

Support by U.S. National Science Foundation under Grants GK-26030 and ENG 75-14848 is gratefully acknowledged.

#### APPENDIX I.—REFERENCES

1. Barnard, P. R., "The Collapse of Reinforced Concrete Beams," International Symposium on the Flexural Mechanics of Reinforced Concrete, Miami, Fla., Nov, 1964, *American Concrete Institute Special Publication No. 12*, Detroit, Mich., 1965, pp. 501-520.
2. Barnard, P. R., and Johnson, R. P., "Plastic Behavior of Continuous Composite Beams," *Proceedings, The Institution of Civil Engineers*, Vol. 32, 1965, pp. 180-197; Discussion by R. H. Wood, Vol. 34, 1966, pp. 577-579.
3. Bažant, Z. P., "L'instabilité d'un milieu continu et la résistance en compression," *Bulletin RILEM*, (Réunion Internationale des Laboratoires d'Essais et de Recherches sur les Matériaux et les Constructions) Paris, France, No. 35, 1967, pp. 99-112.
4. Bažant, Z. P., "On Instability of Three-Dimensional Bodies," *Acta Polytechnica ČVUT*, Prague, Czechoslovakia, Vol. 1, No. 3, 1967, pp. 5-17.
5. Bažant, Z. P., "Conditions of Deformation Instability of a Continuum and their Application to Thick Slabs and a Half-Space" (in Czech), *Stavebnický Časopis SAV*, Vol. 16, 1968, 48-64.
6. Brown, C. B., and Mostaghel, N., "Modulus and Strength of Reinforced Matrices: Critical Values of Inclusion Concentration," *Journal of Materials American Society for Testing and Materials*, Vol. 2, 1967, pp. 120-145.
7. Červenka, V., and Gerstle, K. H., "Inelastic Analysis of Reinforced Concrete Panels,"

- Publications*, International Association for Bridge and Structural Engineering, Vol. 31-II, 1971, pp. 31-45, and Vol. 32-II, 1972, pp. 25-39 (see also *Study No. 8, Inelasticity and Nonlinearity in Structural Concrete*, M. Z. Cohn, Ed., University of Waterloo Press, Waterloo, Ontario, Canada, 1972, pp. 333-344).
8. Dougill, J. W., "A Mathematical Model for Progressive Failure of Cement Paste and Mortar," *Magazine of Concrete Research*, Vol. 19, 1967, pp. 135-142; see also Vol. 23, 1971, pp. 5-9.
  9. Ghosh, S. K., and Cohn, M. Z., "Nonlinear Analysis of Strain-Softening Structures," *Inelasticity and Nonlinearity in Structural Concrete*, M. Z. Cohn, ed., *Study No. 8*, University of Waterloo Press, Waterloo, Ontario, Canada, 1972, pp. 315-332.
  10. Glucklich, J., and Cohen, L. J., "Size as a Factor in the Brittle-Ductile Transition and the Strength of Some Materials," *International Journal of Fracture Mechanics*, Vol. 3, Dec., 1967, pp. 278-289.
  11. Glucklich, J., and Cohen, L. J., "Strain-Energy and Size Effects in a Brittle Material," *Materials Research and Standards*, American Society for Testing and Materials, Vol. 2, Oct., 1968, pp. 17-22.
  12. Hadamard, J., Chapt. VI, *Leçons sur la propagation des ondes*, Hermann, Paris, France, 1903.
  13. Hill, R., "On Uniqueness and Stability in the Theory of Finite Strain," *Journal of the Mechanics and Physics of Solids*, Vol. 5, 1957, pp. 229-241.
  14. Maier, G., "On Structural Instability Due to Strain-Softening," International Union of Theoretical and Applied Mathematics Symposium on Instability of Continuous Systems, Herrenhalb, Germany, Sept., 1969, Springer Verlag, Berlin, West Germany, 1971, pp. 411-417.
  15. Maier, G., Zavelani, A., and Dotreppe, J. C., "Equilibrium Branching due Flexural Softening," *Journal of the Engineering Mechanics Division*, ASCE, Vol. 99, No. EM4, Proc. Paper 9898, Aug., 1973, pp. 897-901.
  16. Palmer, A. C., and Rice, J. R., "The Growth of Slip Surfaces in the Progressive Failure of Overconsolidated Clay," *Proceedings of the Royal Society*, London, England, Series A, Vol. 332, 1973, pp. 527-548.
  17. Popovics, S., "A Numerical Approach to the Complete Stress-Strain Curve of Concrete," *Cement and Concrete Research*, Vol. 3, 1973, pp. 583-599.
  18. Rice, J. R., "The Initiation and Growth of Shear Bands," *Plasticity and Soil Mechanics*, A. C. Palmer, ed., Cambridge University Engineering Department, Cambridge, England, 1973, pp. 263-274.
  19. Rosenblueth, E., and Diaz de Cossio, R., "Instability Considerations in Limit Design of Concrete Frames," International Symposium on the Flexural Mechanics of Reinforced Concrete, Miami, Fla., Nov., 1964 *American Concrete Institute Special Publication No. 12*, Detroit, Mich., 1965, pp. 439-456.
  20. Shinozuka, M., "Probabilistic Modeling of Concrete Structures," *Journal of the Engineering Mechanics Division*, ASCE, Vol. 98, No. EM6, Proc. Paper 9448, Dec., 1972, pp. 1433-1452.
  21. Truesdell, C., and Noll, W., "The Nonlinear Theories of Mechanics," *Encyclopedia of Physics*, Vol. III/3, S. Flüge, ed., Springer, Berlin, West Germany, 1965.
  22. Uppal, J. Y., and Kemp, K. O., "An Instability Theory of Failure for Concrete," *Magazine of Concrete Research*, Vol. 25, 1973, pp. 21-30.
  23. Walsh, P. F., "Fracture of Plain Concrete," *The Indian Concrete Journal*, Vol. 46, Nov., 1972, pp. 469, 470, 476.
  24. Wood, R. H., "Some Controversial and Curious Developments in the Plastic Theory of Structures," *Engineering Plasticity*, J. Heyman and F. A. Leckie, eds., Cambridge University Press, Cambridge, England, 1968, pp. 665-691.

## APPENDIX II.—NOTATIONS

The following symbols are used in this paper:

- A = area of cross section;
- C = spring constant of support;

- $d$  = size of inhomogeneities (e.g., aggregate);
- $E, E_t$  = tangent moduli for loading or unloading and for declining branch;
- $h$  = depth of cross section of beam;
- $k$  = curvature of beam;
- $L$  = length of specimen or beam;
- $l_1$  = length of segment of localization of strain or curvature;
- $M$  = bending moment;
- $n$  = empirical coefficient (between 1 and 20);
- $P^0, p^0$  = initial axial load or distributed load;
- $R, R_t$  = tangent bending rigidities for loading or unloading and for declining branch;
- $u, w$  = axial displacement and deflection;
- $W$  = work;
- $x$  = length coordinate of beam;
- $\delta$  = variation sign;
- $\epsilon, \sigma$  = strain and stress;
- $\phi$  = rotation of ends of beam; and
- 0 = superscript referring to initial state.