



## Evaluation of radiation damage using nonlinear ultrasound

K. H. Matlack, J. J. Wall, J.-Y. Kim, J. Qu, L. J. Jacobs et al.

Citation: *J. Appl. Phys.* **111**, 054911 (2012); doi: 10.1063/1.3692086

View online: <http://dx.doi.org/10.1063/1.3692086>

View Table of Contents: <http://jap.aip.org/resource/1/JAPIAU/v111/i5>

Published by the [American Institute of Physics](#).

---

### Related Articles

Neutron doping effects in epitaxially laterally overgrown n-GaN  
*Appl. Phys. Lett.* **98**, 212107 (2011)

A study of radiation damage effects on the magnetic structure of bulk Iron  
*J. Appl. Phys.* **109**, 07E120 (2011)

Continuous distribution of defect states and band gap narrowing in neutron irradiated GaAs  
*J. Appl. Phys.* **107**, 123710 (2010)

Neutron-irradiated Schottky diodes with self-assembled InAs quantum dots: Optical and electrical properties  
*J. Appl. Phys.* **105**, 104308 (2009)

Model of defect reactions and the influence of clustering in pulse-neutron-irradiated Si  
*J. Appl. Phys.* **104**, 044507 (2008)

---

### Additional information on *J. Appl. Phys.*

Journal Homepage: <http://jap.aip.org/>

Journal Information: [http://jap.aip.org/about/about\\_the\\_journal](http://jap.aip.org/about/about_the_journal)

Top downloads: [http://jap.aip.org/features/most\\_downloaded](http://jap.aip.org/features/most_downloaded)

Information for Authors: <http://jap.aip.org/authors>

## ADVERTISEMENT



## FIND THE NEEDLE IN THE HIRING HAYSTACK

Post jobs and reach  
thousands of hard-to-find  
scientists with specific skills



<http://careers.physicstoday.org/post.cfm>

**physicstoday** JOBS

## Evaluation of radiation damage using nonlinear ultrasound

K. H. Matlack,<sup>1,a)</sup> J. J. Wall,<sup>1,2</sup> J.-Y. Kim,<sup>3</sup> J. Qu,<sup>4</sup> L. J. Jacobs,<sup>1,3</sup> and H.-W. Viehrig<sup>5</sup>

<sup>1</sup>*G.W. Woodruff School of Mechanical Engineering, Georgia Institute of Technology, Atlanta, Georgia 30332, USA*

<sup>2</sup>*Electric Power Research Institute, Charlotte, North Carolina 28262, USA*

<sup>3</sup>*School of Civil and Environmental Engineering, Georgia Institute of Technology, Atlanta, Georgia 30332, USA*

<sup>4</sup>*Department of Civil and Environmental Engineering, Northwestern University, Evanston, Illinois 60208, USA*

<sup>5</sup>*Department of Structural Materials, Helmholtz Zentrum Dresden-Rossendorf, Institute of Ion-Beam Physics and Materials Research, P.O. Box 510119, 01314 Dresden, Germany*

(Received 22 November 2011; accepted 8 February 2012; published online 8 March 2012)

Nonlinear ultrasound was used to monitor radiation damage in two reactor pressure vessel (RPV) steels. The microstructural changes associated with radiation damage include changes in dislocation density and the formation of precipitates, and nonlinear ultrasonic waves are known to be sensitive to such changes. Six samples each of two different RPV steels were previously irradiated in the Rheinsberg power reactor to two fluence levels, up to  $10^{20}$  n/cm<sup>2</sup> ( $E > 1$  MeV). Longitudinal waves were used to measure the acoustic nonlinearity in these samples, and the results show a clear increase in the measured acoustic nonlinearity from the unirradiated state to the medium dose, and then a decrease from medium dose to high dose. © 2012 American Institute of Physics. [<http://dx.doi.org/10.1063/1.3692086>]

### I. INTRODUCTION

Many nuclear reactors throughout the United States are approaching their operational design limit, and there is a need to monitor the material state and remaining life of components to extend their lifetimes. The quantitative nondestructive evaluation of reactor pressure vessel (RPV) components can help prevent premature shut-downs of reactors, while also helping to prevent catastrophic failure. Irradiation of steels causes various microstructural changes that lead to embrittlement of the material. For example, with increasing dose, Meslin *et al.*<sup>1</sup> saw an order of magnitude increase in dislocation loop number density in pure Fe and Fe-Cu alloys and observed an increase of radiation-induced defect size with increasing dose. Miller *et al.*<sup>2</sup> saw an increase in the number density of Ni, Si, and Mn nanoclusters in a high nickel content RPV steel with increasing dose, which were found to be segregated to dislocations at the highest fluence. They explained that nanoclusters impeding the motion of dislocations caused irradiation hardening. Kocik *et al.*<sup>3</sup> saw irradiation-induced defects in RPV steels in the form of dislocation loops and small precipitates that exhibited increasing density and diameter with increasing dose, but found a saturation of these parameters at higher neutron fluences. They saw a roughly constant dislocation density with increasing dose. The saturation of dislocation density<sup>1,3</sup> as a function of dose can be explained by different processes that control dislocation evolution.<sup>4</sup>

Nonlinear ultrasound (NLU) has the potential to monitor irradiation damage in RPV steels, since microstructural changes such as increasing dislocation density and precipitate growth caused by radiation damage have previously been shown to be sensitive to NLU measurements.<sup>5–7</sup> Dislocations

and precipitates produce local atomic strain fields due to their geometric incompatibility with the existing crystal structure. Strain fields are a strong nonlinear function of the geometric parameters and therefore, when perturbed by ultrasonic waves, dislocations and precipitates act as a localized source of nonlinear body forces that generate the higher harmonics in an initially monochromatic ultrasonic signal. Irradiation damage has potentially multiple influences on acoustic nonlinearity, for example, changing dislocation density and nanocluster formation that impedes motion of dislocations.

When a pure sinusoidal ultrasonic wave propagates through a nonlinear medium, higher harmonic wave components are produced. It is known that the acoustic nonlinearity parameter,  $\beta$ , has the following relation:

$$\beta = \frac{8A_2}{\kappa^2 A_1^2 x}, \quad (1)$$

where  $A_1$  is the amplitude of the first harmonic wave,  $A_2$  is the amplitude of the second harmonic wave,  $\kappa$  is the wave-number, and  $x$  is the propagation distance.<sup>5</sup> It has been shown that  $\beta$  is sensitive to increasing plasticity in damage mechanisms such as fatigue,<sup>8</sup> cold work,<sup>9</sup> and creep.<sup>10</sup> The objective of this research is to demonstrate to what extent NLU is sensitive to radiation damage in RPV steels.

### II. MATERIAL SAMPLES

NLU experiments were run on two sets of reference steel materials referred to as “JRQ” and “JFL.” Note that these materials were used in a previous IAEA investigation.<sup>11</sup> These steels are ASTM standard A533B Cl.1 (IAEA reference material code “JRQ”) and A508 Cl.3 (IAEA reference material code “JFL”), with chemical compositions shown in Table I, and they have been reported on in the literature.<sup>11,12</sup> Samples

<sup>a)</sup>Electronic mail: katie.matlack@gatech.edu.

TABLE I. Chemical composition (wt. %) of JRQ and JFL materials.

Material	C	Si	Mn	Cr	Mo	Ni	P	Cu	S
JRQ	0.18	0.24	1.42	0.12	0.51	0.84	0.017	0.14	0.004
JFL	0.17	0.25	1.42	0.16	0.52	0.75	0.004	0.01	0.002

were irradiated at the Rheinsberg power reactor to two dose levels, up to a neutron fluence of  $10^{20}$  n/cm<sup>2</sup> ( $E > 1$  MeV), at a coolant temperature of 255 °C.<sup>13</sup> The samples were of standard Charpy-V geometry (10 mm × 10 mm × 55 mm). Prior to NLU measurements, the unirradiated specimens were wet ground with 600 grit abrasive paper and the irradiated specimens were wet ground with a specially designed grinding machine with 240 grit abrasive paper. The significance of wet grinding the samples is to decrease specimen surface roughness and make the surfaces of the specimens more uniform. Since unirradiated samples were wet ground to a finer grit than irradiated samples, there should be less surface roughness on unirradiated samples. Since surface roughness causes variation in the acoustic nonlinearity parameter in longitudinal wave measurements, the variation in beta in irradiated samples due to surface roughness should be greater. The thickness of the samples varied by 2%.

### III. NONLINEAR ULTRASONIC MEASUREMENTS

The NLU measurements were performed in a hot cell laboratory at Helmholtz Zentrum Dresden-Rossendorf (HZDR) in Dresden, Germany. Staff at HZDR handled the setup of samples and transducers in a specially designed fixture for each measurement, Fig. 1. Two commercial lithium niobate transducers, with diameter of 6.35 mm, were mounted on opposite sides of the steel samples to transmit and receive an ultrasonic bulk wave through the thickness (along the 10 mm dimension). Light oil coupling was used between the transducer faces and the sample surface. A RITEC high power amplifier (SNAP-5000) excited the transmitting transducer (center frequency 2.5 MHz) with a 15-cycle sinusoidal wave at 2.25 MHz. The receiving transducer had a center frequency of 5 MHz. The received signal was then transferred to an oscilloscope (Tektronix TDS 5034B) and then to a computer

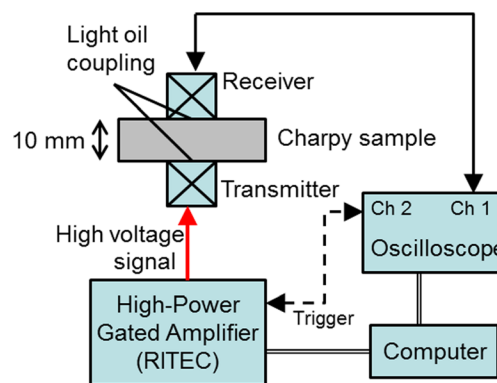

FIG. 1. (Color online) Schematic of experimental setup.

for post-processing. The amplitudes of the first and second harmonic waves,  $A_1$  and  $A_2$ , were obtained by taking a fast Fourier transform (FFT) of the windowed signal. Figure 2 shows a typical measured time-domain signal and its respective FFT. Note that the full signal did not fit in the thickness of the sample, but the FFT was done on only the first 8 cycles of the signal to eliminate contributions from reflected waves. The purpose of using a relatively long signal was to obtain a higher energy acoustic wave and eliminate ringing effects at the end of the signal. The output level of the amplifier was increased in 5% increments from 40–90% full power, and the slope of  $A_2/A_1^2$  was calculated – this slope is a relative measure of the acoustic nonlinearity parameter,  $\beta$ , as defined in Eq. (1). An example of the measurement data for the first and second harmonic amplitudes is shown in Fig. 3, illustrating the linearity of the  $A_2$  to  $A_1^2$  relationship.

### IV. RESULTS AND DISCUSSION

The dependence of the acoustic nonlinearity parameter,  $\beta$ , on neutron fluence is shown in Fig. 4. Each data point in Fig. 4 represents separate measurements on three different samples of the same material and fluence level, and the error bars represent the standard deviation of acoustic nonlinearity over the three samples. While  $\beta$  for both JRQ and JFL is normalized by the unirradiated state, note that the  $\beta$  in unirradiated JFL material was 17% higher than for unirradiated JRQ.

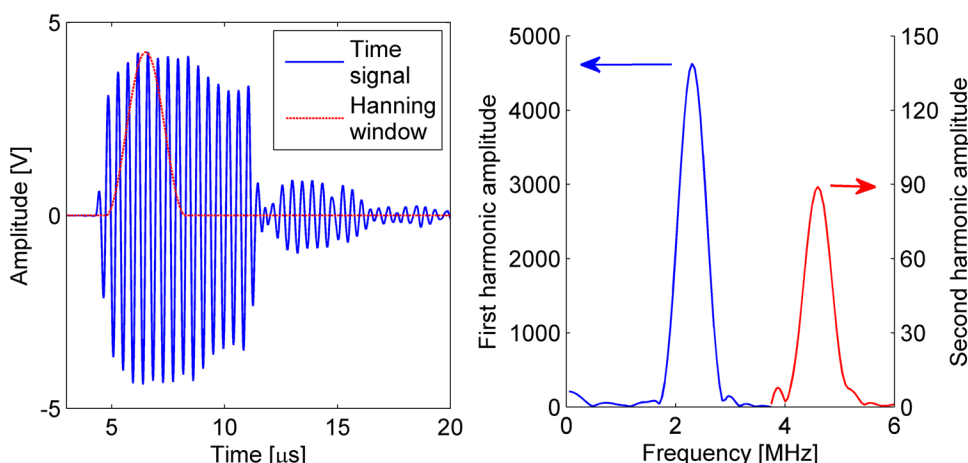

FIG. 2. (Color online) Time signal (left) and corresponding FFT (right) for representative NLU measurement.

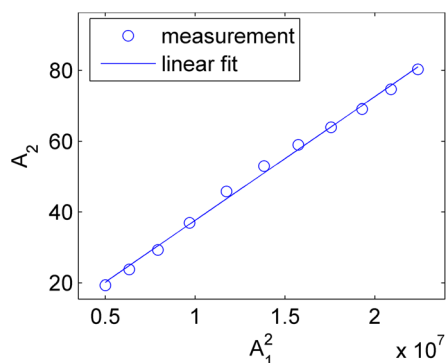

FIG. 3. (Color online) Example of linearity of  $A_2$  to  $A_1^2$  relationship for a measurement on JRQ material at fluence of  $54 \times 10^{18} \text{ n/cm}^2$  ( $E > 1 \text{ MeV}$ ).

There is an increase in  $\beta$  from the unirradiated state to the medium dose samples, then a decrease from medium dose to high dose. It is important to note that the measured  $\beta$  for the high dose samples is still larger than the unirradiated samples. The initial increase in  $\beta$  is larger in the JRQ samples than the JFL samples, which is not surprising as JRQ material is more susceptible to radiation embrittlement. It is important to note that the same trend in  $\beta$  as a function of fluence is seen for the two different types of steel. The results in Fig. 4 were corrected for diffraction of the first harmonic wave propagating through material with slightly varying thicknesses. The variation in  $\beta$  for different specimens at the same fluence level ranged from 8–30%. This variation was primarily due to sample surface conditions, which was confirmed by experiments on polished unirradiated samples. The remainder of the measurement variability was caused by slight variations in coupling and clamping force.

The increase in  $\beta$  from unirradiated to medium dose is due to an increase in dislocation density. Previous work has shown a link between increasing dislocation density and increasing  $\beta$ <sup>6,8</sup> and it has been established that neutron radiation can cause changes in dislocation density.<sup>1–3</sup> The decrease in  $\beta$  is presumably due to the formation of nanoclusters at high doses. While the dislocation density is saturated with the increase of fluence level, more and more nanoclusters (Cu- and others) are formed. As reported by Miller *et al.*,<sup>2</sup> these nanoclusters tend to impede the motion of dislocations and the material has a higher resistance against plastic deformation (and thus lower toughness and higher strength). This impeding action of nanoclusters also has an influence on  $\beta$  since the dislocations are only a source of acoustic nonlinearity when they can freely vibrate when excited by a high amplitude ultrasonic wave. Therefore, the formation of nanoclusters that reduce the mobility of dislocations can be the cause of the reduced nonlinearity at high fluence, as shown in Fig. 4. In fact, it has been shown that dislocations in a copper crystal sample are pinned and thus are immobilized when irradiated at a very low fluence level, which leads to a large decrease of acoustic nonlinearity.<sup>14</sup>

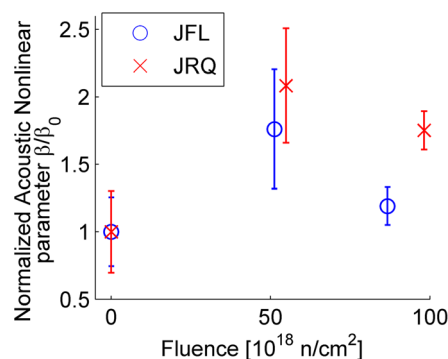

FIG. 4. (Color online) Dependence of acoustic nonlinearity on neutron fluence for JRQ and JFL steel.

The results in Fig. 4 show no clear relation of acoustic nonlinearity with other published material characterizations of irradiation damage of these RPV steels. For example, previous small angle neutron scattering (SANS) measurements on these irradiated samples show that volume fraction of irradiation defects increases linearly with increasing dose.<sup>12</sup> Charpy-V experiments show embrittlement with an increase in transition temperature with increasing dose. Further, the yield stress and ultimate tensile stress increased with increasing dose.<sup>15</sup> More microstructure characterizations are needed to fully explain these results to link  $\beta$  to irradiation damage.

## ACKNOWLEDGMENTS

This work was supported by the National Science Foundation through a Graduate Research Fellowship to Kathryn Matlack. The authors would like to thank Tobias Berndt, with SINCOS Analytics LLC and RITEC Inc., for providing the amplification system for these measurements, and also the technical staff at HZDR for their help in preparing and handling the radioactive samples.

- <sup>1</sup>E. Meslin, M. Lambrecht, M. Hernandez-Mayoral, F. Bergner, L. Malerba, P. Pareige, B. Radiguet, A. Barbu, D. Gomez-Briceno, A. Ulbricht, and A. Almazouzi, *J. Nucl. Mater.* **406**, 73 (2010).
- <sup>2</sup>M. K. Miller, A. A. Chernobaeva, Y. I. Shtrombakh, K. F. Russell, R. K. Nanstad, D. Y. Erak, and O. O. Zabusov, *J. Nucl. Mater.* **385**, 615 (2009).
- <sup>3</sup>J. Kocik, E. Keilova, J. Cizek, and I. Prochazka, *J. Nucl. Mater.* **303**, 52 (2002).
- <sup>4</sup>W. G. Wolfer, *J. Nucl. Mater.* **90**, 175 (1980).
- <sup>5</sup>A. Hikata, B. B. Chick, and C. Elbaum, *J. Appl. Phys.* **36**(1), 229 (1965).
- <sup>6</sup>J. H. Cantrell, *Proc. R. Soc. London, Ser. A* **460**(2043), 757 (2004).
- <sup>7</sup>J. H. Cantrell and W. T. Yost, *Appl. Phys. Lett.* **77**(13), 1952 (2000).
- <sup>8</sup>J.-Y. Kim, L. J. Jacobs, J. Qu, and J. W. Little, *J. Acoust. Soc. Am.* **120**(3), 1266 (2006).
- <sup>9</sup>A. Viswanath, B. P. C. Rao, S. Mahadevan, P. Parameswaran, T. Jayakumar, and B. Raj, *J. Mater. Process. Technol.* **211**, 538 (2011).
- <sup>10</sup>S. Baby, B. N. Kowmudi, C. M. Omprakash, D. V. V. Satyanarayana, K. Balasubramaniam, and V. Kumar, *Scr. Mater.* **59**(8), 818 (2008).
- <sup>11</sup>IAEA, IAEA-TECDOC-1230, 2001.
- <sup>12</sup>A. Ulbricht, J. Bohmert, and H.-W. Viehrig, *J. ASTM Int.* **2**(10), 301 (2005).
- <sup>13</sup>H.-W. Viehrig and C. Zurbuchen, Report No. FZD-4762007, 2007.
- <sup>14</sup>M. A. Breazeale and J. Ford, *J. Appl. Phys.* **36**(11), 3486 (1965).
- <sup>15</sup>C. Zurbuchen, H.-W. Viehrig, and F. P. Weiss, *Nucl. Eng. Des.* **239**, 1246 (2009).